

MANDATORY SERVICE BULLETIN

MSB 42-095

MSB 42NG-026

I TECHNICAL DETAILS

I.1 Category

Mandatory.

I.2 Airplanes affected

Type: DA 42, DA 42 M, DA 42 NG, DA 42 M-NG

Serial numbers: 42.004 through 42.321, 42.324 through 42.347,
42.349, 42.351, 42.353 through 42.357,
42.359 through 42.386, 42.388, 42.389, 42.391,
42.394, 42.396, 42.399, 42.405 through 42.409,
42.412 through 42.416, 42.427,
42.AC001 through 42.AC152,
42.M001 through 42.M011, 42.M015 through 42.M019,
42.M021, 42.M022,
42.N001 through 42.N011, 42.N013, 42.N018, 42.N019,
42.N023 through 42.N028,
42MN001 through 42.MN008
provided that damper D60-3277-10-00_01 has NOT been installed
on both MLG legs

I.3 Date of effectivity

11-Nov-2011

I.4 Time of Compliance

Within 200 flight hours, but not later than 31-Dec-2012.

I.5 Subject

Replacement of MLG damper nut.

ATA-Code: 32-10

I.6 Reason

In one case the nut in the MLG damper has loosened itself during operation. This might lead to the MLG leg getting jammed in the gear bay. This Service Bulletin describes the work necessary to secure the nut in the MLG damper.

Note: Diamond Aircraft Industries recommends doing RSB 42-089 / RSB 42NG-017. The measures prescribed by this service bulletin are included in RSB 42-089 / RSB 42NG-017.

I.7 Concurrent Documents

None.

I.8 Approval

The technical information or instructions contained in this document relate to the Design Change Advisory No. MAM 42-434, which has been approved under the authority of EASA Design Organization Approval ref. EASA.21J.052.

The technical content of this document has been approved under the authority of DOA ref. EASA.21J.052.

I.9 Accomplishments / Instructions

If RSB 42-089 / RSB 42NG-017 has been done on both MLG dampers:

Record MSB 42-095 / MSB 42NG-026 as performed.

Note: Doing RSB 42-089 / RSB 42NG-017 on both MLG dampers is included in Work Instruction "Conversion to DA 42 NG / M-NG" Rev. 7 and later.

If RSB 42-089 / RSB 42NG-017 has **not** been done on both MLG dampers:

Comply with WI-MSB 42-095 / MSB 42NG-026, latest effective issue.

Note: WI-MSB 42-095 / MSB 42NG-026 is attached to this document.

Note: Diamond Aircraft Industries recommends to do RSB 42-089 / RSB 42NG-017 on both MLG dampers. The measures prescribed by this service bulletin are included in RSB 42-089 / RSB 42NG-017.

I.10 Mass (Weight) and CG

The change in mass and CG is negligible.

II PLANNING INFORMATION

II.1 Material and Availability

See WI-MSB 42-095 / MSB 42NG-026, latest effective issue.

Materials including drawings are available from Diamond Aircraft Industries.

II.2 Special Tools

None.

II.3 Labour Effort

Approx. 2 hours.

II.4 Credit

For all AC within warranty period:

2 man hours of work.

Material according to WI-MSB 42-095 / MSB 42NG-026, latest effective issue.

II.5 Reference Documents

Diamond Aircraft DA 42 Series Airplane Maintenance Manual, Doc. No. 7.01.01, latest effective issue.

Diamond Aircraft DA 42 NG Airplane Maintenance Manual, Doc. No. 7.01.15, latest effective issue.

III REMARKS

1. All work must be done by a certified aircraft service station or a certified aircraft maintenance mechanic.
2. All work, particular those that are not especially described in this Service Bulletin, must be done in accordance with the referenced Maintenance Manual.
3. Completion of all work must be recorded in the log book.
4. If material and/or labor hours are subject to be credited through Diamond Aircraft Industries, the Service Bulletin must be carried out by an authorized Diamond Service Center and the Warranty Application incl. Work Report must be sent not later than 30 days after the end of time of compliance.
5. In case of doubt contact Diamond Aircraft Industries GmbH.

**EXECUTION REPORT TO
SERVICE BULLETIN
MSB 42-095
MSB 42NG-026**

AIRPLANE DATA

Airplane Serial Number: _____

Airplane Registration: _____

Airplane Operator: _____

Hours of operation of airplane: _____

No. of landings: _____

Hours of operation-engine: LH _____

RH _____

Typical operation of airplane: private, club, training, other _____

Date, Name, SignPlease fax the completed form to Fax No. +43-2622-26700-1369 or e-mail to
airworthiness@diamond-air.at

WORK INSTRUCTION

WI-MSB 42-095 / WI-MSB 42NG-026

Replacement of self-locking nut in MLG damper

I GENERAL INFORMATION

I.1 Subject

Replacement of nut in MLG damper

I.2 Reference Documents

Diamond Aircraft DA 42 Series Airplane Maintenance Manual, Doc. No. 7.02.01, latest effective issue.

Diamond Aircraft DA 42 NG Airplane Maintenance Manual, Doc. No. 7.02.15, latest effective issue.

I.3 Remarks

- a) All work must be done by a certified aircraft service station or a certified aircraft maintenance mechanic.
- b) All work, particular those that are not especially described in this work instruction, must be done in accordance with the referenced maintenance manual.
- c) For conversion factors between SI and US/Imperial units refer to AMM Chapter 02.
- d) It is recommended to print this Work Instruction in color.
- e) In case of doubt, contact Diamond Aircraft Industries GmbH.

II DRAWINGS, SPECIAL TOOLS & MATERIALS

II.1 Drawings

D60-3277-10-00_01

II.2 Special Tools

Spacer X00-W027-00-00.02 Rev."-"

II.3 Material

Quantity	Part No.	Description
2	ORAR00227-N7083	O-Ring
2	MS 28775-010	O-Ring
2	LN 9348-08	Hexagon nut
2	LN 9348-06	Hexagon nut
100ml	1U-9891 or equivalent	Additiv 1U-9891 Caterpillar Inc.

Materials including special tools are available from Diamond Aircraft Industries.

II.4 Consumables

Quantity	Part No.	Description
Approx. 2 l	3627020L	Aero Shell Fluid 41
a. r.	Royoco 81MS	Grease Royoco 81MS
a. r.	135376	Loctite 262

Consumables may be procured locally or from Diamond Aircraft Industries

III INSTRUCTIONS

1	Make sure AMM-TR-MÄM-42-368 and AMM-TR-MÄM-42-447 are incorporated into the AMM.
2	Remove the LH Main Landing Gear Damper acc. to AMM section 32-10.
3	<p>Release nitrogen and oil from the damper.</p> <p>WARNING: Do not spill Fluid 41 on your skin or on your clothes. Fluid 41 is harmful and can cause skin disease and damage to clothes.</p> <p>WARNING: Always wear safety glasses. The damper is gas loaded.</p> <ul style="list-style-type: none"> • Install the adapter with drain hose onto the charging valve of the damper and release the pressure into the suitable container acc. to picture 1. • Wait until the nitrogen is fully released. • Push in the damper to minimum position to drain the oil. <div data-bbox="1075 1473 1378 1912" data-label="Image">  </div> <p style="text-align: right;">Picture 1</p>
4	Remove the charging valve from damper and install spacer.

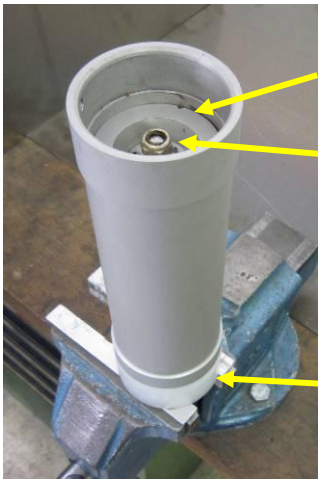
5	<p>Remove the bottom cap:</p> <ul style="list-style-type: none"> Remove the bolt holding the bottom cap. Pull the bottom cap from the damper assembly. <p>WARNING: Do not spill Fluid 41 on your skin or on your clothes. Fluid 41 is harmful and can cause skin disease and damage to clothes.</p> <p>Note: Catch the residual oil into a suitable container.</p> <ul style="list-style-type: none"> Clean the cap with acetone. Replace the O-Ring from the cap by new O-Ring ORAR00227-N7083 and apply a coat of Additive 1U-9891 on the new O-Ring. <p>Caution: Do not use steel tools when removing the O-Ring. Do not scratch the surfaces of the groove.</p>
6	Remove the nut on the piston end plate.
7	<p>Install nut LN 9348-08 on the piston end plate. Secure the connection with Loctite 262 i.a.w. drawing D60-3277-10-00_01.</p> <div style="text-align: center;">  <p>Piston end plate Nut Spacer</p> <p>Picture 2</p> </div>
8	Allow Loctite to cure before filling (Minimum cure time 12 hours).
9	Install the bottom cap with the bolt, washer and nut.
10	Remove the spacer from piston tube.
11	Install the charging valve with a new O-Ring MS 28775-010.
12	<p>Adjust the direction of the piston tube to the cylinder tube acc. to picture 3.</p> <p>Note: The charging valve must be aligned with the nut from the bolt holding the bottom cap.</p>

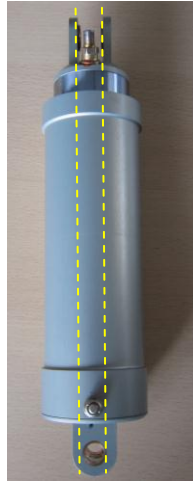

Picture 3

13	Fill and charge the Damper acc. to AMM Section 32-10.
14	Install the Damper to the MLG acc. to AMM Section 32-10.
15	Perform steps 2 through 14 on the RH MLG damper.
16	Clean working area and check for foreign objects.
17	Do a landing gear extension and retraction test and check clearance between MLG wheel and wheel bay i.a.w. AMM Section 32-10.
18	Apply anti-corrosion coating on damper connections i.a.w. AMM Section 12-30.
19	Perform functional check of altered, repaired and new parts.
20	Test all systems in working area for function.
21	Make necessary entries into aircraft logs.

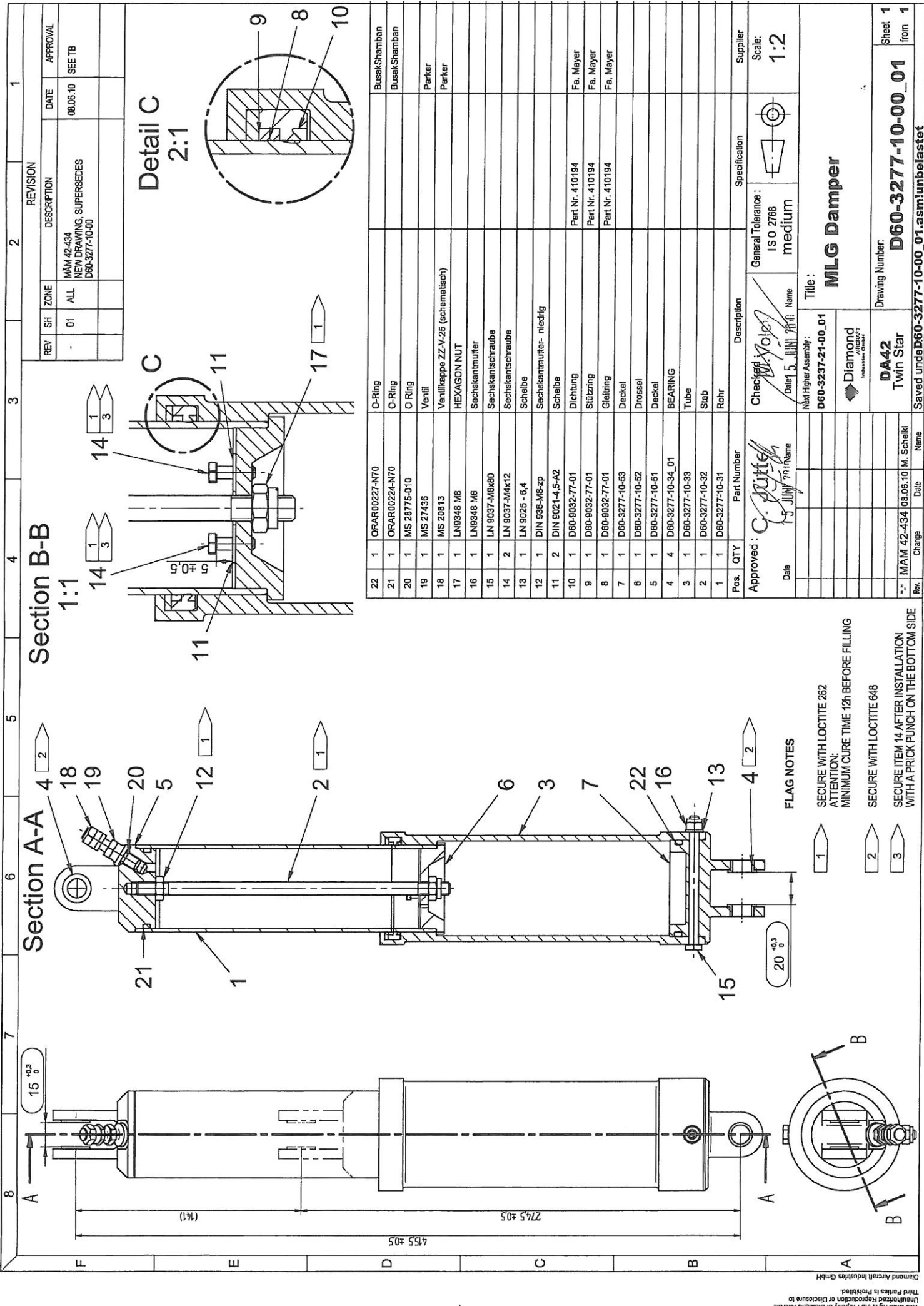

Section A-A

1:1

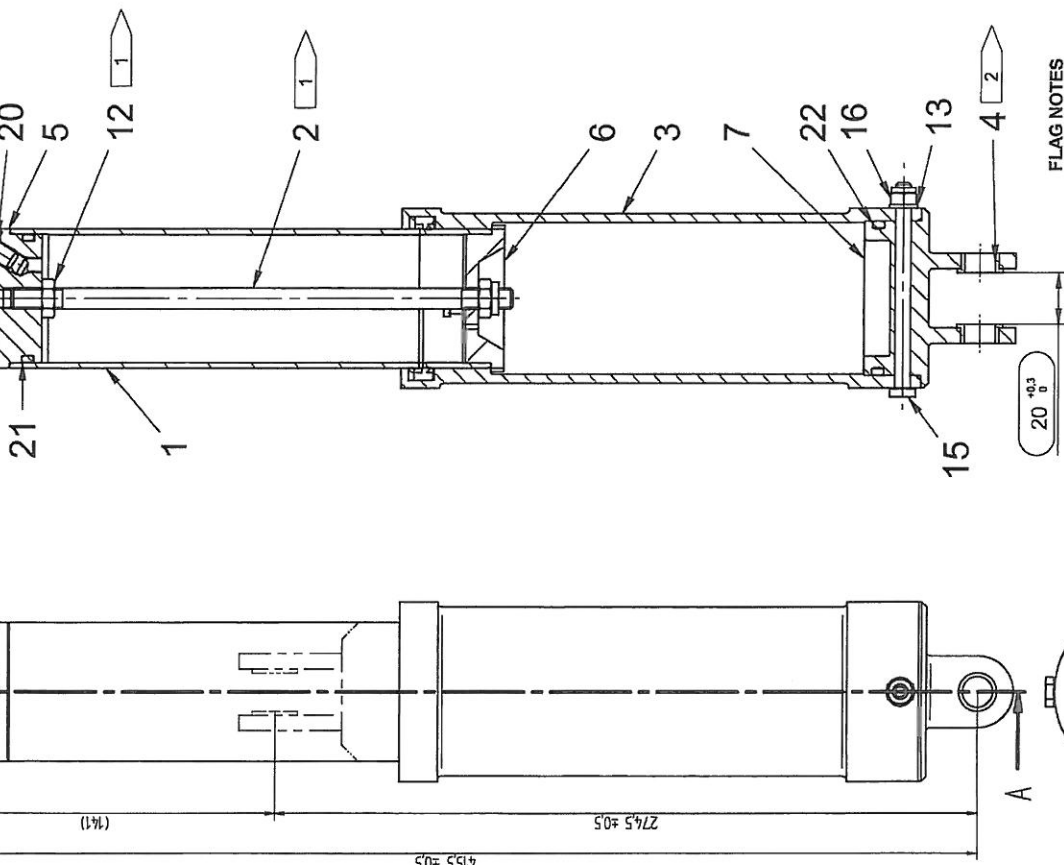

FLAG NOTES

- 1 SECURE WITH LOCTITE 262
ATTENTION:
MINIMUM CURE TIME 12h BEFORE FILLING
- 2 SECURE WITH LOCTITE 648
- 3 SECURE ITEM 14 AFTER INSTALLATION
WITH A PRICK PUNCH ON THE BOTTOM SIDE

Section B-B

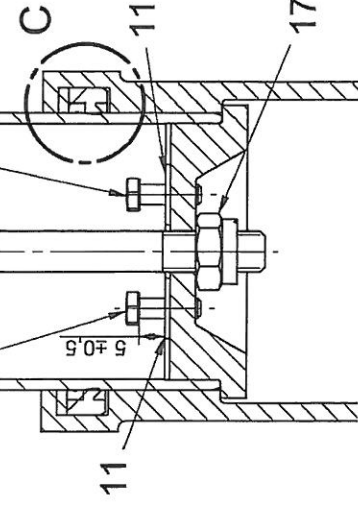

Detail C

2:1

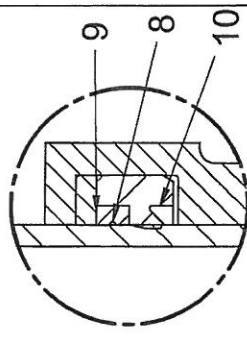

REV	SH	ZONE	DESCRIPTION	DATE	APPROVAL
-	01	ALL	MAM 42-434 NEW DRAWING, SUPERSEDES D60-3277-10-00	08.06.10	SEE TB

Pos.	QTY	Part Number	Description	Specification	Supplier
22	1	ORAR00227-N70	O-Ring		BusekShamban
21	1	ORAR00224-N70	O-Ring		BusekShamban
20	1	MS 28775-010	O Ring		
19	1	MS 27436	Ventil		Parker
18	1	MS 20813	Ventilklappe ZZ-V-25 (schematisch)		Parker
17	1	LN8348 M8	HEXAGON NUT		
16	1	LN8348 M6	Sechskantmutter		
15	1	LN 9037-M6x80	Sechskantschraube		
14	2	LN 9037-M6x12	Sechskantschraube		
13	1	LN 9025 - 6,4	Scheibe		
12	1	DIN 936-M6-zp	Sechskantmutter- niedrig		
11	2	DIN 9021-4,5-A2	Scheibe		
10	1	D60-9032-77-01	Dichtung		Fa. Mayer
9	1	D60-9032-77-01	Stütznng	Part Nr. 410194	Fa. Mayer
8	1	D60-9032-77-01	Gleitring	Part Nr. 410194	Fa. Mayer
7	1	D60-3277-10-53	Deckel	Part Nr. 410194	Fa. Mayer
6	1	D60-3277-10-52	Drossel		
5	1	D60-3277-10-51	Deckel		
4	4	D60-3277-10-34_01	BEARING		
3	1	D60-3277-10-33	Tube		
2	1	D60-3277-10-32	Stab		
1	1	D60-3277-10-31	Rohr		

Checked	Date	Name	Title
<i>[Signature]</i>	15 JUNI 2010		MLG Damper

Next Higher Assembly:	General Tolerance:	Scale:
D60-3237-21-00_01	ISO 2768 medium	1:2

Rev.	Change	Date	Name
1	MAM 42-434	08.06.10	M. Scheiki

Drawing Number:	Supplier
D60-3277-10-00_01	BusekShamban

Sheet	from
1	1