

# RECOMMENDED SERVICE BULLETIN

## RSB 42-089/1

## RSB 42NG-017/1

### SUPERSEDES RSB 42-089 / RSB 42NG-017

## **I TECHNICAL DETAILS**

### **I.1 Category**

Recommended.

### **I.2 Airplanes affected**

Type: DA 42, DA 42 M, DA 42 NG, DA 42 M-NG  
Serial numbers: 42.004 through 42.321, 42.324 through 42.347,  
42.349, 42.351, 42.353 through 42.357,  
42.359 through 42.386, 42.388, 42.389, 42.391,  
42.394, 42.396, 42.399, 42.405 through 42.409,  
42.412 through 42.416, 42.427,  
42.AC001 through 42.AC152,  
42.M001 through 42.M011, 42.M015 through 42.M019,  
42.M021, 42.M022,  
42.N001 through 42.N011, 42.N013, 42.N018,  
42.N019, 42.N023 through 42.N028,  
42MN001 through 42.MN008  
provided that a damper D60-3277-10-00\_01 has NOT yet been  
installed

### **I.3 Date of effectivity**

06-Oct-2010

### **I.4 Time of Compliance**

At owner's discretion.

### **I.5 Subject**

Replacement of seals in main landing gear damper.  
ATA-Code: 32-10

## **I.6 Reason**

The new seal system for the main landing gear damper offers more durability in a greater temperature range.

Note: This Service Bulletin's instruction, material and labor effort relate to work on one MLG damper only.

## **I.7 Concurrent Documents**

None.

## **I.8 Approval**

The technical information or instructions contained in this document relate to the Design Change Advisory No. MÄM 42-434, which has been approved under the authority of EASA Design Organization Approval ref. EASA.21J.052.

The technical content of this document has been approved under the authority of DOA ref. EASA.21J.052.

## **I.9 Accomplishments / Instructions**

Comply with WI-RSB 42-089 / WI-RSB 42NG-017, latest effective issue.

Note: WI-RSB 42-089 / WI-RSB 42NG-017 is attached to this document.

Note: This Service Bulletin's instruction, material and labor effort relate to work on one MLG damper only.

## **I.10 Mass (Weight) and CG**

None.

# **II PLANNING INFORMATION**

## **II.1 Material and Availability**

See WI-RSB 42-089 / WI-RSB 42NG-017, latest effective issue.

Materials including drawings are available from Diamond Aircraft Industries.

Note: This Service Bulletin's instruction, material and labor effort relate to work on one MLG damper only.

## **II.2 Special Tools**

See WI-RSB 42-089 / WI-RSB 42NG-017, latest effective issue.

## **II.3 Labor Effort**

Approx. 1.5 hours for upgrade and installation.

Note: This Service Bulletin's instruction, material and labour effort relate to work on one MLG damper only.

## **II.4 Credit**

For airplanes within warranty per damper:

1.5 hours of labor and material as listed in WI-RSB 42-089 / WI-RSB 42NG-017 II.3.

## **II.5 Reference Documents**

Diamond Aircraft 42 Series Airplane Maintenance Manual, Doc. No. 7.02.01, latest effective issue.

Diamond Aircraft 42 NG Airplane Maintenance Manual, Doc. No. 7.02.15, latest effective issue.

## **III REMARKS**

1. All measures must be carried out by a certified aircraft service station or a certified aircraft maintenance mechanic.
2. All works, in particular those that are not especially described in this Service Bulletin, must be carried out in accordance with the referenced Maintenance Manual.
3. Accomplishment of the measures must be confirmed in the log book.
4. If material and/or labor hours are subject to be credited through Diamond Aircraft Industries, the Service Bulletin must be carried out by an authorized Diamond Service Center and the Warranty Application incl. Work Report must be sent not later than 30 days after the end of time of compliance.
5. In case of doubt contact Diamond Aircraft Industries GmbH.



Diamond Aircraft Industries GmbH  
N. A. Otto-Straße 5  
A-2700 Wiener Neustadt  
Austria

DAI RSB 42-089/1  
DAI RSB 42NG-017/1  
Page 4 of 4  
19-Apr-2011

## EXECUTION REPORT TO SERVICE BULLETIN RSB 42-089/1 RSB 42NG-017/1

### AIRPLANE DATA

Airplane Serial Number: \_\_\_\_\_

Airplane Registration: \_\_\_\_\_

Airplane Operator: \_\_\_\_\_

Hours of operation of airplane: \_\_\_\_\_

No. of landings: \_\_\_\_\_

Hours of operation-engine      LH      \_\_\_\_\_

   RH      \_\_\_\_\_

Typical operation of airplane:      private, club, training, other \_\_\_\_\_

Modified damper       LH       RH

\_\_\_\_\_  
Date, Name, Sign

Please fax the completed form to Fax No. +43-2622-26700-1369 or e-mail to  
airworthiness@diamond-air.at

## WORK INSTRUCTION

WI-RSB 42-089

WI-RSB 42NG-017

### Installation of sealing ring with greater temperature range

#### **I GENERAL INFORMATION**

##### **I.1 Subject**

Replacement of main landing gear damper seals to allow a greater temperature range.

##### **I.2 Reference Documents**

Diamond Aircraft DA 42 Series Airplane Maintenance Manual, Doc. No. 7.02.01, latest effective issue.

Diamond Aircraft DA 42 NG Airplane Maintenance Manual, Doc. No. 7.02.15, latest effective issue.

##### **I.3 Remarks**

- a) The work must be carried out by a certified aircraft service station or a certified aircraft maintenance mechanic.
- b) All works, particular those that are not especially described in this work instruction, must be carried out in accordance with the referenced maintenance manual.
- c) For conversion factors between SI and US/Imperial units refer to AMM Chapter 02.
- d) It is recommended to print this Work Instruction in color.
- e) This Work Instruction including material and labor effort relate to work on one MLG damper only.
- f) In case of doubt, contact Diamond Aircraft Industries GmbH.

## II DRAWINGS, SPECIAL TOOLS & MATERIALS

### II.1 Drawings

D60-3277-10-00\_01

### II.2 Special Tools

Centering pin: X00-W027-00-00.01 Rev."-"  
 Spacer: X00-W027-00-00.02 Rev."-"  
 Damper Drain Tool: D60-3277-10-00-ST or equivalent  
 Seal pick: D60-3277-10-01-ST or equivalent

### II.3 Material

Quantity	Part No.	Description
1	D60-9032-77-01	Tandem Seal
1	ORAR00227-N7083	O-Ring
1	ORAR00224-N7083	O-Ring
1	MS 28775-010	O-Ring
1	LN9348 M8	Hexagon nut
1	LN9348 M6	Hexagon nut
100ml	1U-9891 or equivalent	Additiv 1U-9891 Caterpillar Inc.

Materials including special tools are available from Diamond Aircraft Industries.

Note: This list includes material only for one damper.

### II.4 Consumables



Quantity	Part No.	Description
1l	3627020L	Aero Shell Fluid 41
a. r.	Royoco 81MS	Grease Royoco 81MS
a. r.	N000 148 or equivalent	Acetone



Consumables may be procured locally or from Diamond Aircraft Industries



### III INSTRUCTIONS

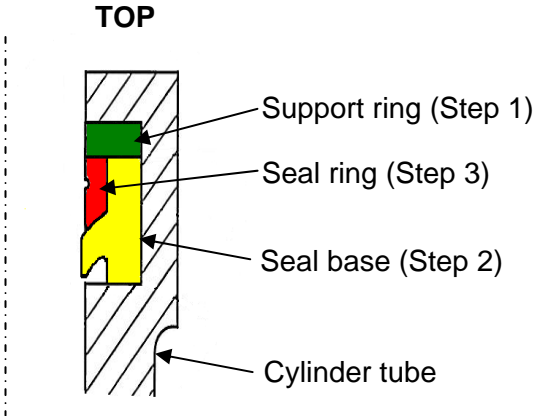

1	Ensure AMM-TR-MÄM-42-368 is incorporated into the AMM.
2	Remove the Main Landing Gear Damper acc. to AMM section 32-10.
3	<p>Release nitrogen and oil from the damper.</p> <p><b>WARNING: Do not spill Fluid 41 on your skin or on your clothes. Fluid 41 is harmful and can cause skin disease and damage to clothes.</b></p> <p><b>WARNING: The damper is gas loaded. Always wear safety glasses.</b></p> <p>Install the adapter with drain hose onto the charging valve of the damper and release the pressure into the suitable container acc. to picture 1.</p> <p>Wait until the nitrogen is fully released.        Push in the damper to minimum position to drain the oil.</p> <div data-bbox="710 969 1007 1406" data-label="Image">  </div> <p style="text-align: center;">Picture1</p>
4	Remove the charging valve from damper.

5	<p>Remove the bottom cap:</p> <ul style="list-style-type: none"> <li>• Remove the bolt holding the bottom cap.</li> <li>• Pull the bottom cap from the damper assembly.</li> </ul> <p><b>WARNING: Do not spill Fluid 41 on your skin or on your clothes. Fluid 41 is harmful and can cause skin disease and damage to clothes.</b></p> <p>Note: Catch the residual oil into a suitable container.</p> <ul style="list-style-type: none"> <li>• Clean the cap with acetone.</li> <li>• Replace the O-Ring from the cap by new O-Ring ORAR00227-N7083 and apply a coat of Additive 1U-9891 on the new O-Ring.</li> </ul> <p><b>Caution: Do not use steel tools when removing the O-Ring. Do not scratch the surfaces of the groove.</b></p>
6	<p>Disassemble piston:</p> <p>Remove the nut on the piston and pull out the piston end plate.</p>
7	<p>Remove the cylinder tube from the piston.</p>
8	<p>Remove the upper cap from the piston.          Clean the upper cap with fresh acetone.          Replace the O-Ring from the upper cap by new O-Ring ORA AR 00224-N7083 and apply a coat of Additive 1U-9891 on the new O-Ring.</p> <p><b>Caution: Do not use steel tools when removing the O-Ring. Do not scratch the surfaces of the groove.</b></p>



<p>9</p>	<p>Remove the quad ring and the two backup rings from the tube:</p> <p><b>Caution: Do not use steel tools when removing the quad ring. Do not scratch the surfaces of the groove.</b></p> <p>Use seal pick D60-3277-10-01-ST to remove the quad ring.        Clean the cylinder tube with acetone.        Examine the grooves of the cylinder tube and the piston tube for scratches and wear.        If scratch and wear are discernible, replace the defective part.</p>  <p style="text-align: center;">Picture 2</p>
<p>10</p>	<p>Description of the new tandem seal kit in the cylinder tube:</p> <div style="display: flex; justify-content: space-around; text-align: center;"> <div data-bbox="411 1151 584 1187">Support- ring</div> <div data-bbox="799 1151 919 1187">Seal ring</div> <div data-bbox="1171 1151 1307 1187">Seal base</div> </div>  <p style="text-align: center;">Picture 3</p> <p><b>Pay attention to mounting direction.</b></p> 
<p>11</p>	<p>Install the support ring. Deform the ring carefully acc. to picture 4.</p> <p><b>CAUTION: Avoid excessive bending of the support ring.</b></p>

	 <p style="text-align: center;">Picture 4</p>
<p>12</p>	<p>Install the seal base below the support ring:          Deform the seal base acc. to picture 5 and install it in the cylinder tube.          Press the seal base into the groove.</p>  <p style="text-align: center;">Picture 5</p>
<p>13</p>	<p>Install the seal ring into the seal base.          Deform the seal ring acc. to picture 6 and install it into the cylinder tube.</p> <p><b>CAUTION: Avoid excessive bending of the seal ring.          Do not crack the seal ring.</b></p> <p>Press the seal ring into the seal base groove.</p>  <p style="text-align: center;">Picture 6</p>
<p>14</p>	<p>Apply a coat of Additive 1U-9891 on the tandem seal kit and the centering pin.</p>

15	<p>Carefully insert the centering pin X00-W027-00-00.01 into the cylinder tube 2 or 3 times to position the tandem seal in the cylinder groove.</p>  <p>Picture 7</p>
16	<p>Examine the connection of the thread rod and upper cap for tight fit. If necessary: Apply Loctite 262 to thread and retighten nut.</p>
17	<p>Install the piston tube on the piston tube end acc. to picture 8. Ensure tight fit.</p>  <p>Picture 8</p>

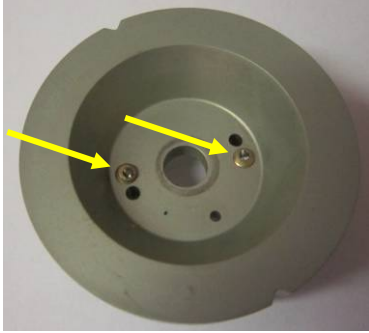
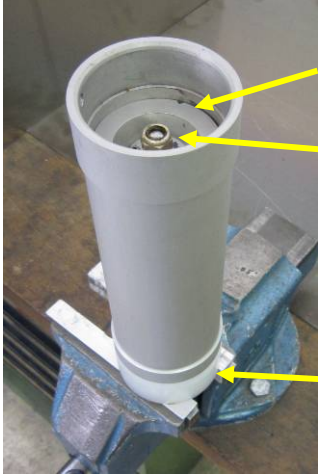
18	<p>Mount the spacer and the centering pin acc. to picture 9.</p>  <p style="text-align: center;">Picture 9</p>
19	<p>Apply a coat of Additiv 1U-9891 on the piston tube and the centering pin.</p>
20	<p>Put the cylinder tube over the centering pin on the piston tube.</p>
21	<p>Remove the centering pin with a M12 bolt.</p>  <p style="text-align: center;">Picture 10</p>
22	<p>Examine the piston end plate: Check the thread excess length of 5 mm between bolt head and restriction washer acc. to picture 11.</p>  <p style="text-align: center;">Picture 11</p>
23	<p>If adjustment is necessary: Remove the bolt and apply a coat of Loctite 262 to the thread and adjust a thread excess length of 5 mm between bolt head and restriction washer acc. to picture 11.</p>

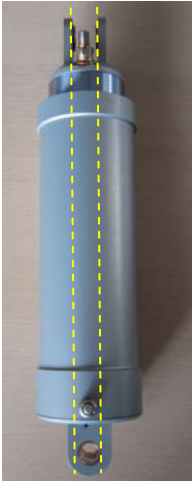
24	<p>Secure the bolt after installation with a prick-punch on the bottom side acc. to picture 12.</p>  <p style="text-align: center;">Picture 12</p>
25	<p>Install the piston end plate in the cylinder tube with a nut LN 9348 M8. Secure the connection with Loctite 262 acc. to drawing D60-3277-10-00_01.</p>  <p style="text-align: center;">Picture 13</p>
26	Remove the spacer from piston tube.
27	Install the bottom cap with the bolt, washer and nut.
28	Install the charging valve with a new O-Ring MS 28775-010.
29	<p>Adjust the direction of the piston tube to the cylinder tube acc. to picture 14.</p> <p>Note: The charging valve must be aligned with the nut from the bolt holding the bottom cap.</p>

	 <p style="text-align: center;">Picture 14</p>
30	Fill and charge the Damper acc. to AMM Section 32-10.
31	Install the Damper to the MLG acc. to AMM Section 32-10.
32	Clean working area and check for foreign objects.
33	<p>Mark the damper with a red point for indication of the installed new seal kit with commercial spray paint (or equivalent).</p>  <p style="text-align: center;">Picture 15</p>
34	Perform a landing gear extension and retraction test and check clearance between MLG wheel and wheel bay acc. to AMM-TR-MÄM-42-447.
35	Apply anti-corrosion coating on damper connections acc. to AMM Section 12-30.
36	Perform functional check of altered, repaired and new parts.
37	Test all systems in working area for function.
38	<p>Make necessary entries into aircraft logs.          Note: Record which MLG damper (LH/RH) has been modified.</p>

This Drawing is the Property of Diamond Aircraft. Unauthorized Reproduction or Disclosure to Third Parties is Prohibited.

Diamond Aircraft Industries GmbH

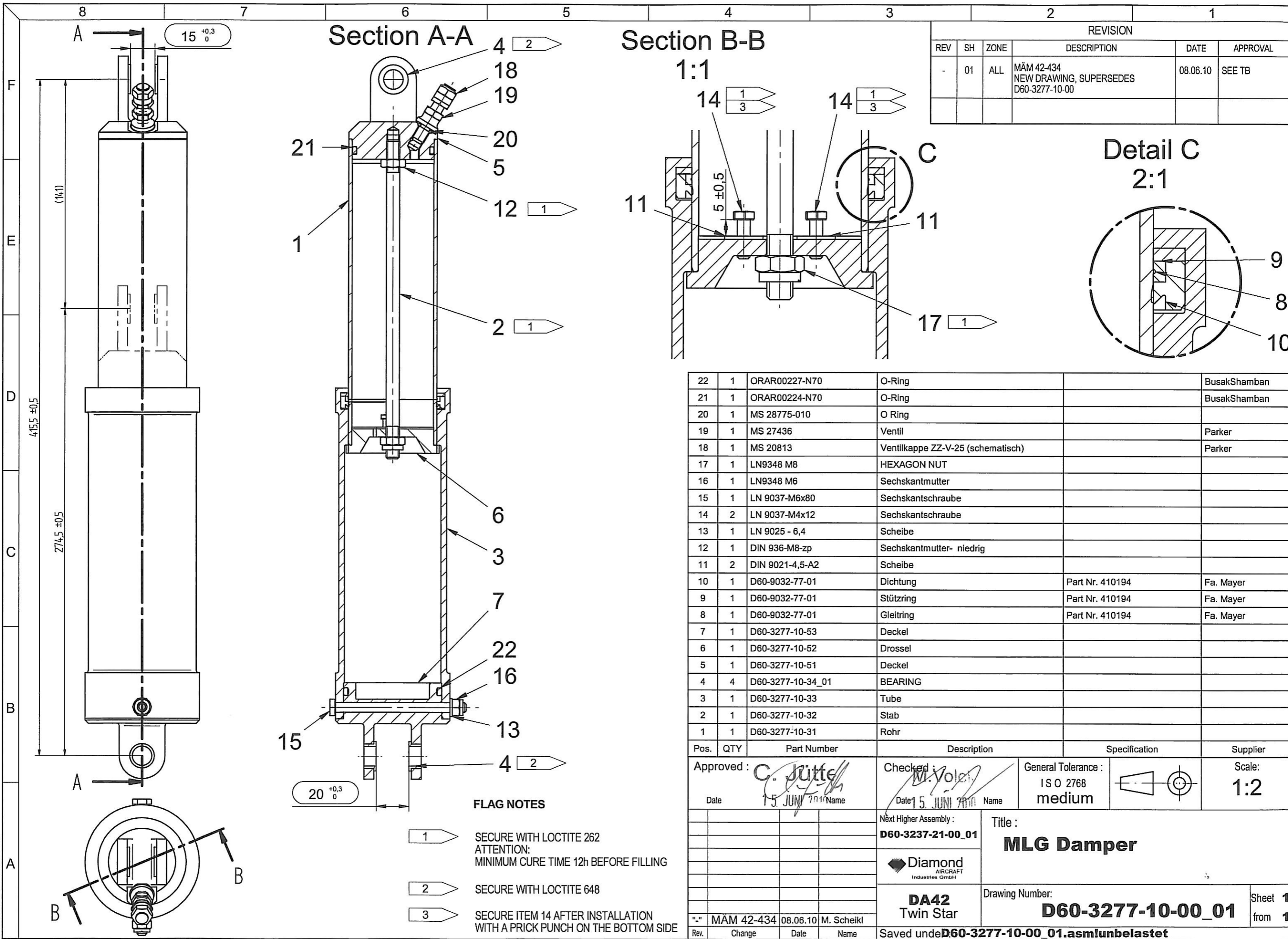

REVISION					
REV	SH	ZONE	DESCRIPTION	DATE	APPROVAL
-	01	ALL	MÄM 42-434 NEW DRAWING, SUPERSEDES D60-3277-10-00	08.06.10	SEE TB

22	1	ORAR00227-N70	O-Ring		BusakShamban
21	1	ORAR00224-N70	O-Ring		BusakShamban
20	1	MS 28775-010	O Ring		
19	1	MS 27436	Ventil		Parker
18	1	MS 20813	Ventilkappe ZZ-V-25 (schematisch)		Parker
17	1	LN9348 M8	HEXAGON NUT		
16	1	LN9348 M6	Sechskantmutter		
15	1	LN 9037-M6x80	Sechskantschraube		
14	2	LN 9037-M4x12	Sechskantschraube		
13	1	LN 9025 - 6,4	Scheibe		
12	1	DIN 936-M8-zp	Sechskantmutter- niedrig		
11	2	DIN 9021-4,5-A2	Scheibe		
10	1	D60-9032-77-01	Dichtung	Part Nr. 410194	Fa. Mayer
9	1	D60-9032-77-01	Stützring	Part Nr. 410194	Fa. Mayer
8	1	D60-9032-77-01	Gleitring	Part Nr. 410194	Fa. Mayer
7	1	D60-3277-10-53	Deckel		
6	1	D60-3277-10-52	Drossel		
5	1	D60-3277-10-51	Deckel		
4	4	D60-3277-10-34_01	BEARING		
3	1	D60-3277-10-33	Tube		
2	1	D60-3277-10-32	Stab		
1	1	D60-3277-10-31	Rohr		

Pos.	QTY	Part Number	Description	Specification	Supplier
Approved: <i>C. Jütte</i>			Checked: <i>M. Volek</i>	General Tolerance: ISO 2768 medium	Scale: 1:2
Date: 15 JUN 2010 Name: M. Scheidl			Date: 15 JUN 2010 Name: M. Volek	Title: <b>MLG Damper</b>	
			Next Higher Assembly: <b>D60-3237-21-00_01</b>	Drawing Number: <b>D60-3277-10-00_01</b>	
			<b>Diamond AIRCRAFT Industries GmbH</b>	Sheet 1 from 1	
			<b>DA42 Twin Star</b>	Saved under <b>D60-3277-10-00_01.asmlunbelastet</b>	
Rev.	Change	Date	Name		

- FLAG NOTES**
- 1 → SECURE WITH LOCTITE 262  
ATTENTION:  
MINIMUM CURE TIME 12h BEFORE FILLING
  - 2 → SECURE WITH LOCTITE 648
  - 3 → SECURE ITEM 14 AFTER INSTALLATION  
WITH A PRICK PUNCH ON THE BOTTOM SIDE