



DA40 NG



airborne innovation

FACTS AND SPECIFICATIONS

DA40 NG facts and specifications

Power plant

Engine	Austro Engine AE 300 turbocharged common-rail injected 2.0 liter diesel engine with 168 HP and EECU single lever control system
Propeller	MT propeller MTV-6-R/190-69 3-blade constant speed propeller
Fuel grades	Jet A-1, Jet A, TS-1 (Russia, Ukraine), RT (Russia, Ukraine), No. 3 Jet Fuel (China), JP-8

Performance (max. mass)

Max. speed (14,000 ft, MCP)	285 km/h TAS	154 kts TAS
Cruise speed at 60% (14,000 ft)	231 km/h TAS	125 kts TAS
Stall speed, landing configuration	107 km/h CAS	58 kts CAS
Rate of climb (ISA SL)	3.5 m/s	690 ft/min
Range at 60% (incl. auxiliary tank)	1,741 km	940 nm
Consumption at 60%	19.7 lt/hr	5.2 US gal/hr
Take-off ground roll (ISA SL)	370 m	1,214 ft
Landing ground roll (ISA SL)	270 m	886 ft
Max. operating altitude	5,000 m	16,400 ft
Max. demonstrated crosswind	46 km/h	25 kts

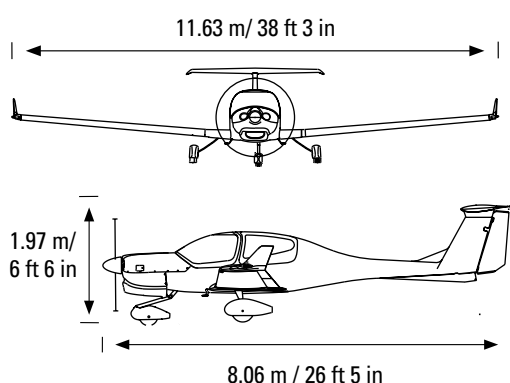

Dimensions / mass / loading

Seats	4	4
Empty weight	900 kg	1,984 lbs
Useful load	410 kg	904 lbs
Max. take off mass	1,310 kg	2,888 lbs
Fuel capacity total	147 lt / 118 kg	39 US gal / 261 lbs
main tank	106 lt / 84 kg	28 US gal / 188 lbs
auxiliary tank	41 lt / 33 kg	11 US gal / 74 lbs

Diamond Aircraft Industries GmbH, Phone: +43 2622 26700 1317, sales@diamond-air.at, www.diamond-air.at
 Specifications apply to standard equipped aircraft, if not otherwise stated. The above data are approximately specifications and may change without notice.

09/2016 S_30613E © 2016 Diamond Aircraft Industries GmbH